

SECTION **PB**  
PARKING BRAKE SYSTEM

A  
B  
C  
D  
E  
PB  
G  
H  
I  
J  
K  
L  
M

CONTENTS

<b>PARKING BRAKE SYSTEM</b> .....	2	<b>PARKING BRAKE SHOE</b> .....	5
On-Vehicle Service .....	2	Components .....	5
PEDAL STROKE .....	2	Removal and Installation .....	5
INSPECT COMPONENTS .....	2	REMOVAL .....	5
ADJUSTMENT .....	2	INSPECTION AFTER REMOVAL .....	6
<b>PARKING BRAKE CONTROL</b> .....	3	INSTALLATION .....	6
Components .....	3	<b>SERVICE DATA AND SPECIFICATIONS (SDS)</b> .....	7
Removal and Installation .....	3	Parking Drum Brake .....	7
REMOVAL .....	3	Parking Brake Control .....	7
INSTALLATION .....	4		

# PARKING BRAKE SYSTEM

## PARKING BRAKE SYSTEM

PFP:36010

### On-Vehicle Service PEDAL STROKE

AFS00182

- When parking brake pedal is operated with a force of 196 N (20 kg, 44 lb), make sure the stroke is within the specified number of notches. (Check it by listening and counting the ratchet clicks.)

**Pedal stroke : 3 to 4 notches**

### INSPECT COMPONENTS

- Make sure the components are attached properly (check for looseness, backlash, etc.).
- Check parking brake pedal assembly for bend, damage and cracks, and replace if necessary.
- Check cable for wear and damage, and replace if necessary.
- Check parking brake warning lamp switch for malfunction, and replace if necessary.

### ADJUSTMENT

- To perform adjustment operations, remove tire from the vehicle with power tool.

1. Insert a deep socket wrench to rotate adjusting nut and loosen the cable sufficiently. Then, return the pedal to the free height.
2. Using wheel nuts, fix the disc to the hub and prevent it from tilting.

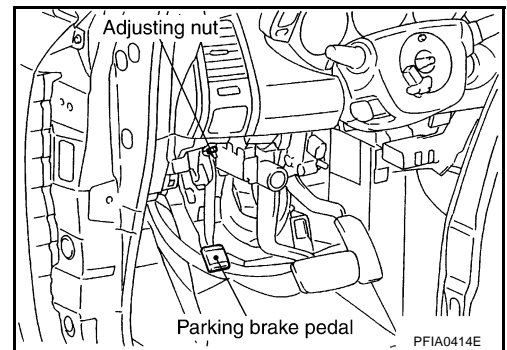

3. Remove adjusting hole plug installed on the disc rotor. Using a screwdriver, turn the adjuster as shown in the figure until the disc rotor is locked. After locking, turn the adjuster in the opposite direction by 5 or 6 notches.
4. Rotate the disc rotor to make sure there is no drag. Install the adjusting hole plug.
5. Adjust cable as follows:
  - a. Operate pedal 10 or more times with a force of 294 N (30 kg, 66 lb).
  - b. Rotate adjusting nut with deep socket to adjust pedal stroke.

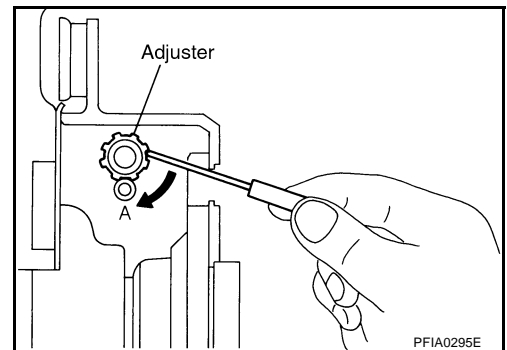

#### NOTE:

Do not reuse the adjusting nut after removing it.

- c. When parking brake pedal is operated with a force of 196 N (20 kg, 44 lb), make sure the stroke is within the specified number of notches. (Check it by listening and counting the ratchet clicks.)

**Pedal stroke : 3 to 4 notches**

- d. With the pedal completely returned, make sure there is no drag on the rear brake.

### Components

AFS00183

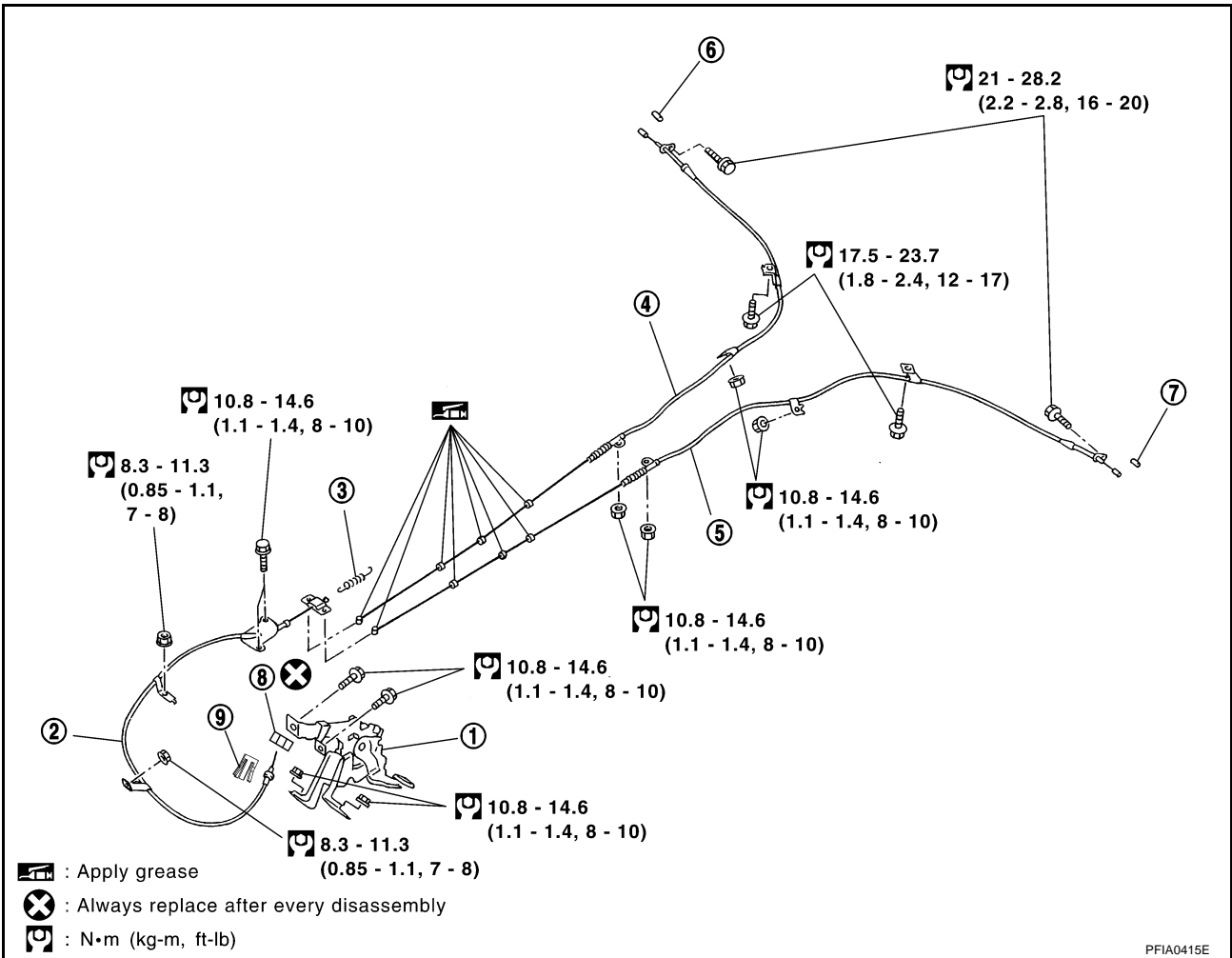

- |                     |                    |                  |
|---------------------|--------------------|------------------|
| 1. Device assembly  | 2. Front cable     | 3. Return spring |
| 4. Rear right cable | 5. Rear left cable | 6. Pin           |
| 7. Pin              | 8. Adjusting nut   | 9. Spring cap    |

### Removal and Installation

#### REMOVAL

AFS00184

1. Remove front kicking plate (driver side). Refer to [EI-32, "BODY SIDE TRIM"](#) .
2. Remove front body side welt (driver side). Refer to [EI-32, "BODY SIDE TRIM"](#) .
3. Remove lower instrument panel (driver side). Refer to [IP-10, "INSTRUMENT PANEL ASSEMBLY"](#) .
4. Remove dash side finisher (driver side). Refer to [EI-32, "BODY SIDE TRIM"](#) .
5. Remove side ventilator assembly (Left). Refer to [IP-10, "INSTRUMENT PANEL ASSEMBLY"](#) .
6. Remove relay box stay fixing screw.
7. Remove parking brake switch connector.
8. Remove adjusting nut.
9. Remove device assembly bolt, nut and remove device assembly from the vehicle.
10. Remove center console. Refer to [IP-17, "CENTER CONSOLE ASSEMBLY"](#) .
11. Remove front cable mounting bolts, nuts and remove front cable from the vehicle.
12. Remove center muffler. Refer to [EX-3, "EXHAUST SYSTEM"](#) .
13. Remove propeller shaft with AWD model. Refer to [PR-4, "REAR PROPELLER SHAFT"](#) .
14. Remove disc rotors. Refer to [BR-34, "Removal and Installation of Brake Caliper Assembly"](#) .
15. Remove rear cable from the toggle lever.

## PARKING BRAKE CONTROL

---

16. Remove right and left rear cable mounting nuts, bolts, and remove right and left rear cable assembly from the vehicle.

### INSTALLATION

1. Refer to "Component Parts Location" for tightening torque. Install in the reverse order of removal.

**NOTE:**

Do not reuse the adjusting nut.

2. Adjust the parking brake. Refer to [PB-2, "ADJUSTMENT"](#) .

# PARKING BRAKE SHOE

## PARKING BRAKE SHOE

PFPA:44060

### Components

AFS00185

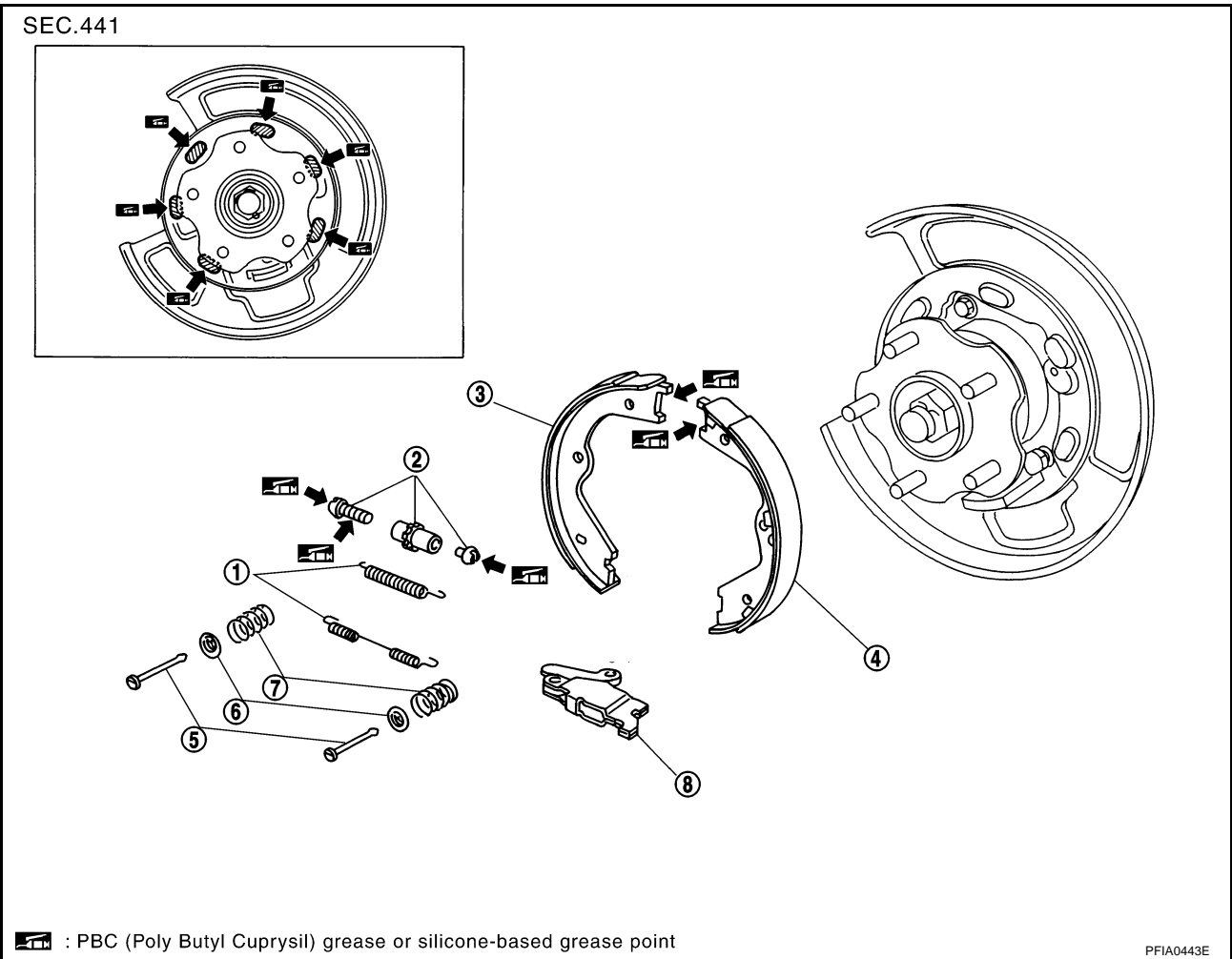

- |                       |                      |                     |
|-----------------------|----------------------|---------------------|
| 1. Return spring      | 2. Adjuster assembly | 3. Shoe (Secondary) |
| 4. Shoe (Primary)     | 5. Anti-rattle pin   | 6. Retainer         |
| 7. Anti-rattle spring | 8. Toggle lever      |                     |

## Removal and Installation

### REMOVAL

AFS00186

#### CAUTION:

Clean dust on the disc and back plate with a vacuum dust collector. Do not blow with compressed air. Be careful of the following:

- Remove the disc rotor only with the parking brake pedal completely in the returned position.
- If disc rotor cannot be removed, remove as follows.

1. Fix the disc rotor in place with wheel nuts and remove disc rotor plug. Using a flat-bladed screwdriver, rotate adjuster wheel on the adjuster assembly in direction B to retract and loosen brake shoes.

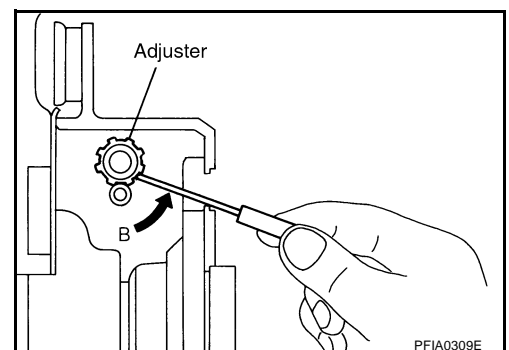

# PARKING BRAKE SHOE

## INSPECTION AFTER REMOVAL

### Lining Thickness Inspection

- Check thickness of lining.

#### Standard

**Standard thickness (A) : 3.2 mm (0.126 in)**

**Repair limit thickness (A) : 1.5 mm (0.059 in)**

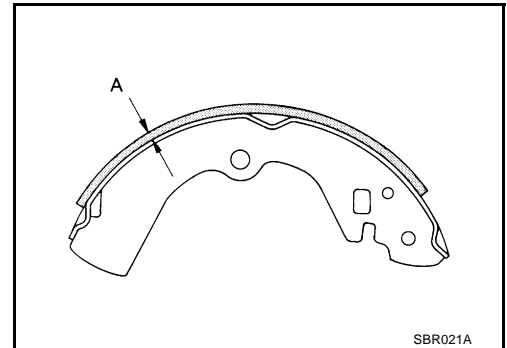

### Drum Inner Diameter Inspection

- Check drum inner diameter.

#### Standard

**Standard inner diameter : 190 mm (7.48 in)**

**Maximum inner diameter : 191 mm (7.52 in)**

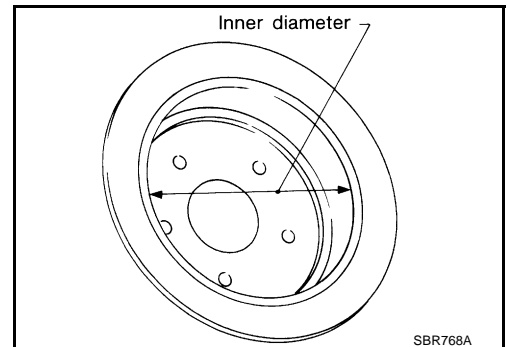

### Other Inspections

- Check shoe sliding surface for excessive wear and damage.
- Check anti-rattle pin for excessive wear and corrosion.
- Check return spring for sagging.
- Does the adjuster move smoothly?
- Check either visually or with a vernier caliper to see if there is any excessive wear, cracks, or damage inside the drum.

## INSTALLATION

Be careful of the following.

- Refer to "Component Parts Location" and apply brake grease to the specified points during assembly.
  - There is difference of the adjusters orientation difference between left and right. Assemble the adjuster so that threaded part expands when rotating it in the direction shown by the arrow.
  - Shorten adjuster by rotating it.
  - When disassembling the adjuster, apply PBC (Poly Butyl Cuprysil) grease or silicone based grease to the threads.
  - After replacing brake shoes or disc rotors, or if brakes do not function well, perform break-in operation as follows.
1. Adjust the parking brake pedal stroke to the specified stroke.
  2. Perform break-in (drag run) operation by driving the vehicle under the following conditions:

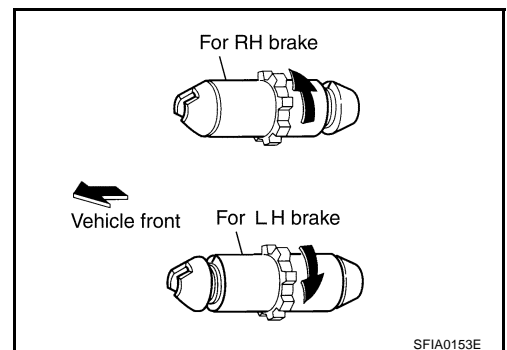

#### Drive forward

- **Vehicle speed approx. 40 km/h (25 MPH) set (forward)**
  - **Parking brake operating force approx. 147 N (15 kg, 33 lb) set**
  - **Distance approx. 100 m (328 ft)**
3. After break-in operation, check lever stroke of the parking brake. Readjust if it is no longer at the specified stroke.
    - To prevent the lining from getting too hot, allow a cool off period of approximately 5 minutes after every break-in operation.
    - Do not perform excessive break-in operations, because it may cause uneven or early wear of the lining.

# SERVICE DATA AND SPECIFICATIONS (SDS)

## SERVICE DATA AND SPECIFICATIONS (SDS)

PFP:00030

### Parking Drum Brake

AFS00187

Type		DS19HC
Brake lining	Standard thickness (new)	3.2 mm (0.126 in)
	Wear limit thickness	1.5 mm (0.059 in)
Drum (disc)	Standard inner diameter (new)	190 mm (7.48 in)
	Wear limit of inner diameter	191 mm (7.52 in)

### Parking Brake Control

AFS00188

Control type	Foot pedal
Number of notches [under a force of 196 N (20 kg, 44 lb)]	3 to 4 notches
Number of notches when warning lamp switch comes on	1 notches

A  
B  
C  
D  
E  
PB  
G  
H  
I  
J  
K  
L  
M

# SERVICE DATA AND SPECIFICATIONS (SDS)

---