

A  
LU  
C  
D  
E

# SECTION **LU**

## ENGINE LUBRICATION SYSTEM

### CONTENTS

<b>PRECAUTIONS</b> .....	<b>2</b>	<b>OIL COOLER</b> .....	<b>10</b>	F
Precautions for Liquid Gasket .....	2	Removal and Installation .....	10	
LIQUID GASKET APPLICATION PROCEDURE....	2	REMOVAL .....	10	
<b>PREPARATION</b> .....	<b>3</b>	INSPECTION AFTER REMOVAL .....	11	G
Special Service Tools .....	3	INSTALLATION .....	11	
Commercial Service Tools .....	3	INSPECTION AFTER INSTALLATION .....	11	
<b>LUBRICATION SYSTEM</b> .....	<b>4</b>	<b>OIL PUMP</b> .....	<b>12</b>	H
Lubrication Circuit .....	4	Removal and Installation .....	12	
System Chart .....	5	REMOVAL .....	12	
<b>ENGINE OIL</b> .....	<b>6</b>	INSTALLATION .....	12	I
Inspection .....	6	INSPECTION AFTER INSTALLATION .....	12	
ENGINE OIL LEVEL .....	6	Disassembly and Assembly .....	12	
ENGINE OIL APPEARANCE .....	6	DISASSEMBLY .....	12	
ENGINE OIL LEAKAGE .....	6	INSPECTION AFTER DISASSEMBLY .....	13	J
OIL PRESSURE CHECK .....	7	ASSEMBLY .....	14	
Changing Engine Oil .....	8	<b>SERVICE DATA AND SPECIFICATIONS (SDS) .....</b>	<b>15</b>	
<b>OIL FILTER</b> .....	<b>9</b>	Standard and Limit .....	15	K
Removal and Installation .....	9	OIL PRESSURE .....	15	
REMOVAL .....	9	ENGINE OIL CAPACITY (APPROXIMATE) .....	15	
INSTALLATION .....	9	OIL PUMP .....	15	L
INSPECTION AFTER INSTALLATION .....	9	REGULATOR VALVE .....	15	

# PRECAUTIONS

---

## PRECAUTIONS

PF0:00001

### Precautions for Liquid Gasket LIQUID GASKET APPLICATION PROCEDURE

ABS004RE

1. Remove old liquid gasket adhering to the liquid gasket application surface and the mating surface.
  - Remove liquid gasket completely from the liquid gasket application surface, mounting bolts, and bolt holes.
2. Wipe the liquid gasket application surface and the mating surface with white gasoline (lighting and heating use) to remove adhering moisture, grease and foreign materials.
3. Apply liquid gasket to the liquid gasket application surface.  
**Use Genuine RTV Silicone Sealant or equivalent. Refer to [GI-48, "RECOMMENDED CHEMICAL PRODUCTS AND SEALANTS"](#) .**
  - Within 5 minutes of liquid gasket application, install the mating component.
  - If liquid gasket protrudes, wipe it off immediately.
  - Do not retighten mounting bolts or nuts after the installation.
  - After 30 minutes or more have passed from the installation, fill engine oil and engine coolant.

# PREPARATION

## PREPARATION

PF0:00002

### Special Service Tools

ABS003MQ

The actual shapes of Kent-Moore tools may differ from those of special service tools illustrated here.

Tool number (Kent-Moore No.) Tool name	Description
ST25051001 (J25695-1) Oil pressure gauge	Measuring oil pressure <b>Maximum measuring range: 2,452 kPa (25 kg/cm<sup>2</sup> , 356 psi)</b>
ST25052000 (J25695-2) Hose	Adapting oil pressure gauge to oil pan (upper)
KV10115801 (J38956) Oil filter wrench	Removing oil filter <b>a: 64.3 mm (2.531 in)</b>
WS39930000 ( — ) Tube presser	Pressing the tube of liquid gasket

## Commercial Service Tools

ABS003MR

Tool name	Description
Power tools	Loosening nuts and bolts
Deep socket	Removing and installing oil pressure switch <b>a: 27 mm (1.06 in)</b>

# LUBRICATION SYSTEM

## LUBRICATION SYSTEM

PFP:15010

### Lubrication Circuit

ABS0035N

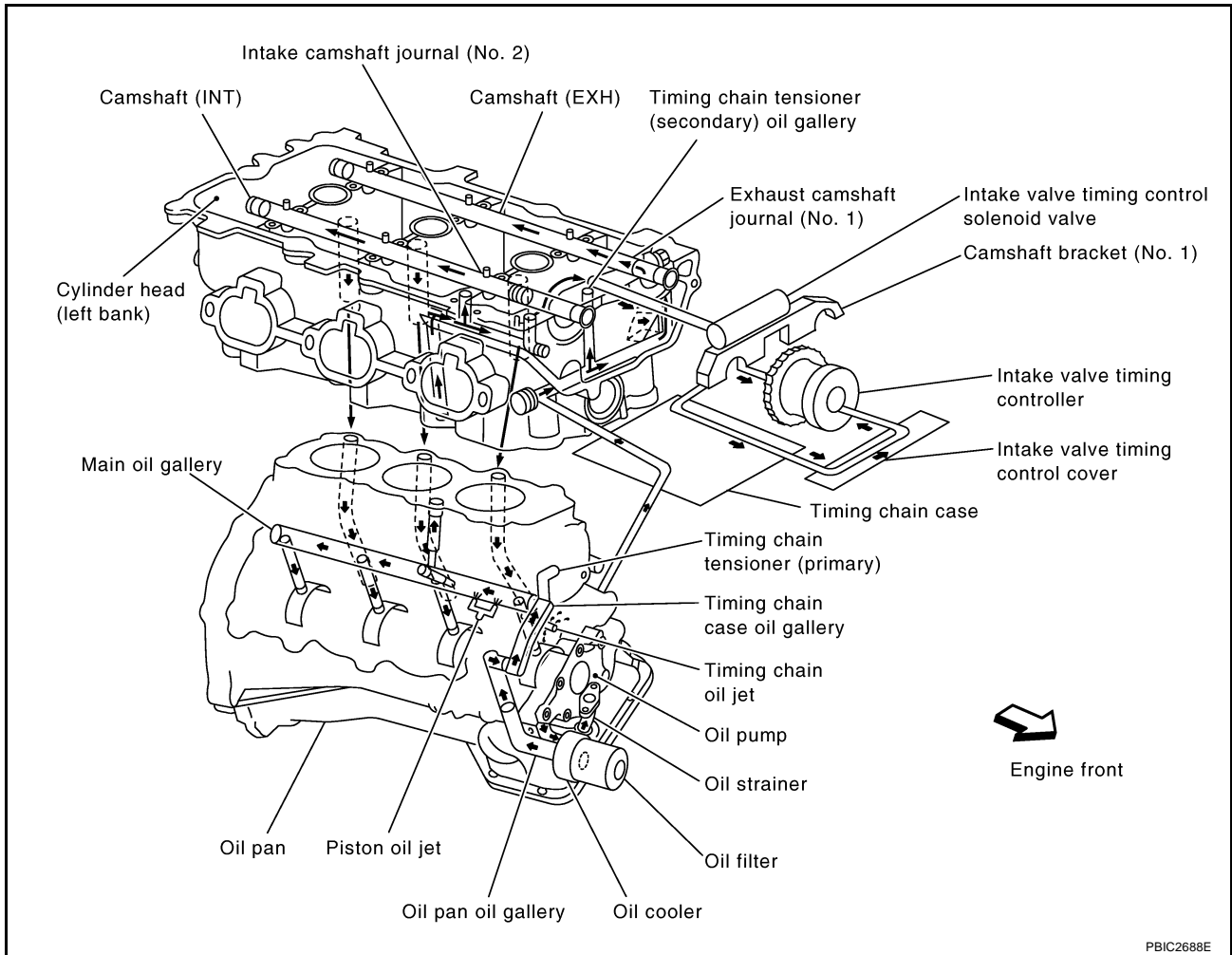

# LUBRICATION SYSTEM

## System Chart

ABS00350

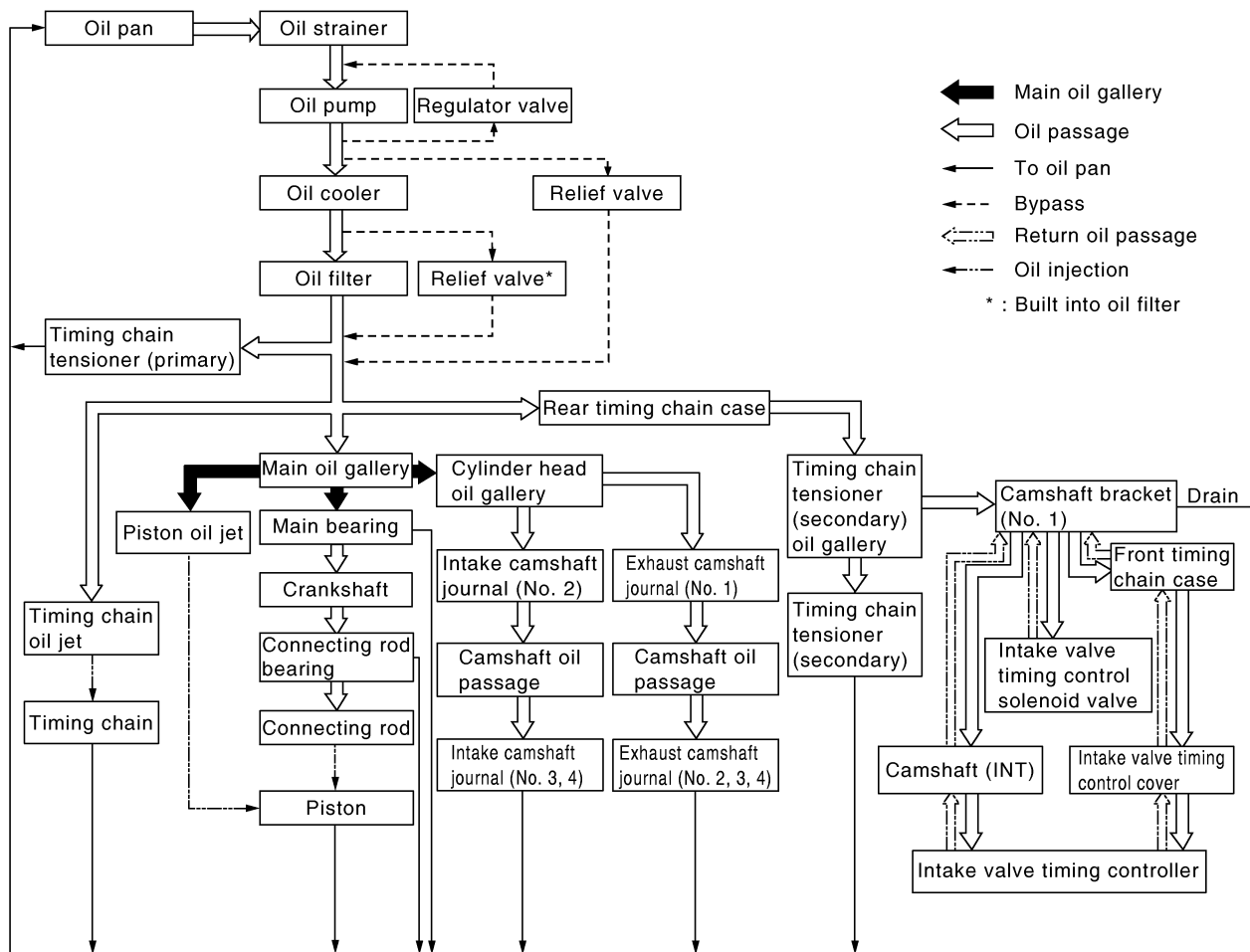

PBIC2689E

A  
LU  
C  
D  
E  
F  
G  
H  
I  
J  
K  
L  
M

## ENGINE OIL

PFP:KLA92

### Inspection ENGINE OIL LEVEL

ABS0035P

#### NOTE:

Before starting engine, put vehicle horizontally and check the engine oil level. If engine is already started, stop it and allow 10 minutes before checking.

1. Pull out oil level gauge and wipe it clean.
2. Insert oil level gauge and make sure the engine oil level is within the range shown in the figure.
3. If it is out of range, adjust it.

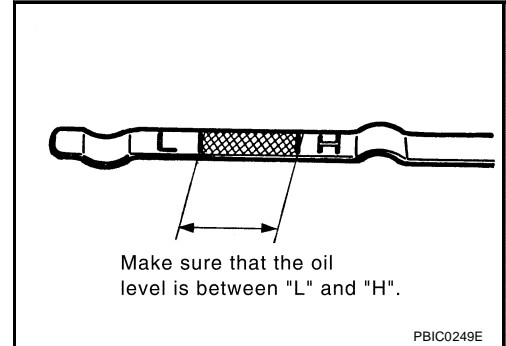

### ENGINE OIL APPEARANCE

- Check engine oil for white turbidity or heavy contamination.
- If engine oil becomes turbid and white, it is highly probable that it is contaminated with engine coolant. Repair or replace damaged parts.

### ENGINE OIL LEAKAGE

Check for engine oil leakage around the following areas:

- Oil pans (lower and upper)
- Oil pan drain plug
- Oil pressure switch
- Oil filter
- Oil cooler
- Water pump cover
- Chain tensioner cover
- Intake valve timing control cover and intake valve timing control solenoid valve
- Mating surface between cylinder head and rocker cover
- Mating surface between front timing chain case and rear timing chain case
- Mating surface between rear timing chain case and cylinder head
- Mating surface between rear timing chain case and cylinder block.
- Mating surface between rear timing chain case and oil pan (upper)
- Mating surface between cylinder block and cylinder head
- Crankshaft oil seals (front and rear)
- Camshaft position sensor (PHASE)

# ENGINE OIL

## OIL PRESSURE CHECK

### WARNING:

- Be careful not to get burn yourself, as engine oil may be hot.
- Oil pressure check should be done in "Parking position".

1. Check the engine oil level. Refer to [LU-6, "ENGINE OIL LEVEL"](#).
2. Remove splash guard (RH).
3. Disconnect harness connector at oil pressure switch, and remove oil pressure switch using deep socket (commercial service tool)

### CAUTION:

Do not drop or shock oil pressure switch.

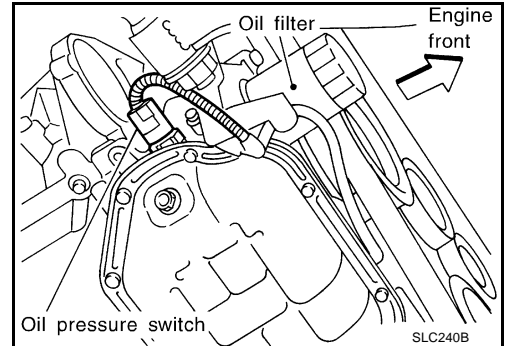

4. Install pressure gauge [SST] and hose [SST].

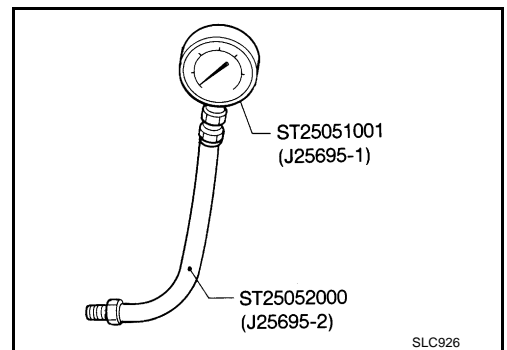

5. Start the engine and warm it up to normal operating temperature.
6. Check the engine oil pressure with engine running under no-load.

### NOTE:

When the engine oil temperature is low, the engine oil pressure becomes high.

### Engine oil pressure [Engine oil temperature at 80°C (176°F)]

Engine speed (rpm)	Approximate discharge pressure [kPa (kg/cm <sup>2</sup> , psi)]
Idle speed	More than 98 (1.0, 14)
2,000	More than 294 (3.0, 43)

**If difference is extreme, check engine oil passage and oil pump for engine oil leaks.**

7. After the inspections, install oil pressure switch as follows:
  - a. Remove old liquid gasket adhering to oil pressure switch and mating surface.
  - b. Apply liquid gasket and tighten oil pressure switch to the specification.

Use Genuine RTV Silicone Sealant or equivalent. Refer to [GI-48, "RECOMMENDED CHEMICAL PRODUCTS AND SEALANTS"](#).

### Oil pressure switch:

: 14.8 N·m (1.5 kg·m, 11 ft·lb)

## Changing Engine Oil

**WARNING:**

- Be careful not to get burn yourself, as engine oil may be hot.
  - Prolonged and repeated contact with used engine oil may cause skin cancer; try to avoid direct skin contact with used engine oil. If skin contact is made, wash thoroughly with soap or hand cleaner as soon as possible.
1. Warm up the engine, and check for engine oil leakage from engine components. Refer to [LU-6, "ENGINE OIL LEAKAGE"](#) .
  2. Stop the engine and wait for 10 minutes.
  3. Loosen oil filler cap, and then remove drain plug.
  4. Drain engine oil.
  5. Install drain plug with new washer. Refer to [EM-28, "OIL PAN AND OIL STRAINER"](#) .

**CAUTION:**

Be sure to clean drain plug and install with new washer.

**Oil pan drain plug:**

 :34.3 N·m (3.5 kg·m, 25 ft·lb)

6. Refill with new engine oil.  
**Engine oil specification and viscosity:**  
 Refer to [MA-11, "RECOMMENDED FLUIDS AND LUBRICANTS"](#) .

**Engine oil capacity (Approximate):**

Unit: ℓ (US qt, Imp qt)

Drain and refill	With oil filter change	4.0 (4-1/4, 3-1/2)
	Without oil filter change	3.7 (3-7/8, 3-1/4)
Dry engine (Overhaul)		5.0 (5-1/4, 4-3/8)

**CAUTION:**

- When filling engine oil, do not pull out oil level gauge.
  - The refill capacity depends on the engine oil temperature and drain time. Use these specifications for reference only.
  - Always use oil level gauge to determine the proper amount of engine oil in engine.
7. Warm up engine and check area around drain plug and oil filter for engine oil leakage.
  8. Stop engine and wait for 10 minutes.
  9. Check the engine oil level. Refer to [LU-6, "ENGINE OIL LEVEL"](#) .

## OIL FILTER

### Removal and Installation

#### REMOVAL

1. Remove splash guard (RH).
2. Using oil filter wrench [SST], remove oil filter.

**CAUTION:**

- Oil filter is provided with relief valve. Use Genuine Nissan Oil Filter or equivalent.
- Be careful not to get burned when engine and engine oil may be hot.
- When removing, prepare a shop cloth to absorb any engine oil leakage or spillage.
- Do not allow engine oil to adhere to drive belts.
- Completely wipe off any engine oil that adheres to engine and vehicle.

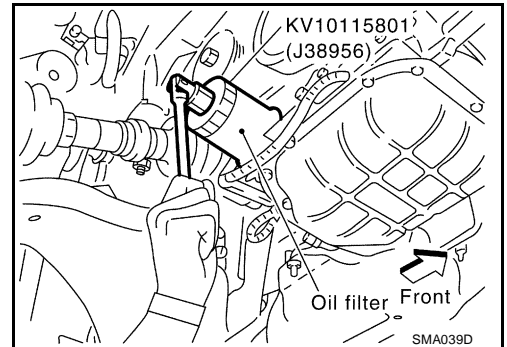

#### INSTALLATION

1. Remove foreign materials adhering to oil filter installation surface.
2. Apply engine oil to the oil seal contact surface of new oil filter.

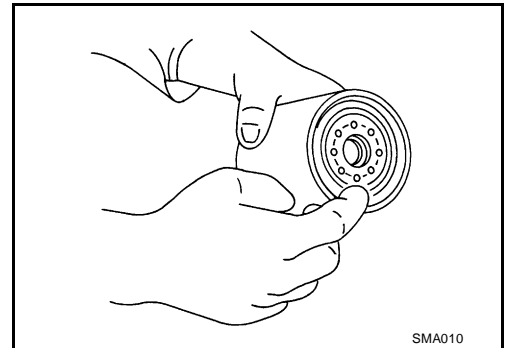

3. Screw oil filter manually until it touches the installation surface, then tighten it by 2/3 turn. Or tighten to the specification.

**Oil filter:**

 : 17.6 N·m (1.8 kg-m, 13 ft-lb)

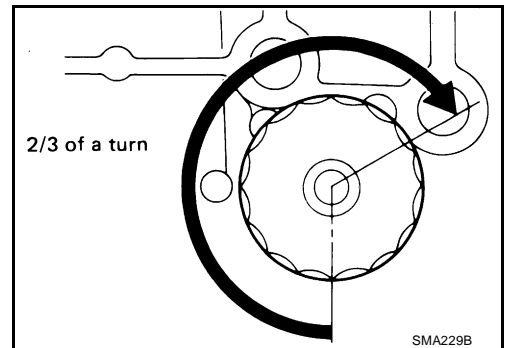

#### INSPECTION AFTER INSTALLATION

1. Check the engine oil level. Refer to [LU-6, "ENGINE OIL"](#).
2. Start engine, and check there is no leak of engine oil.
3. Stop engine and wait for 10 minutes.
4. Check the engine oil level and adjust the level. Refer to [LU-6, "ENGINE OIL"](#).

A  
LU  
C  
D  
E  
F  
G  
H  
I  
J  
K  
L  
M

## OIL COOLER

PFP:21305

### Removal and Installation

ABS0035S

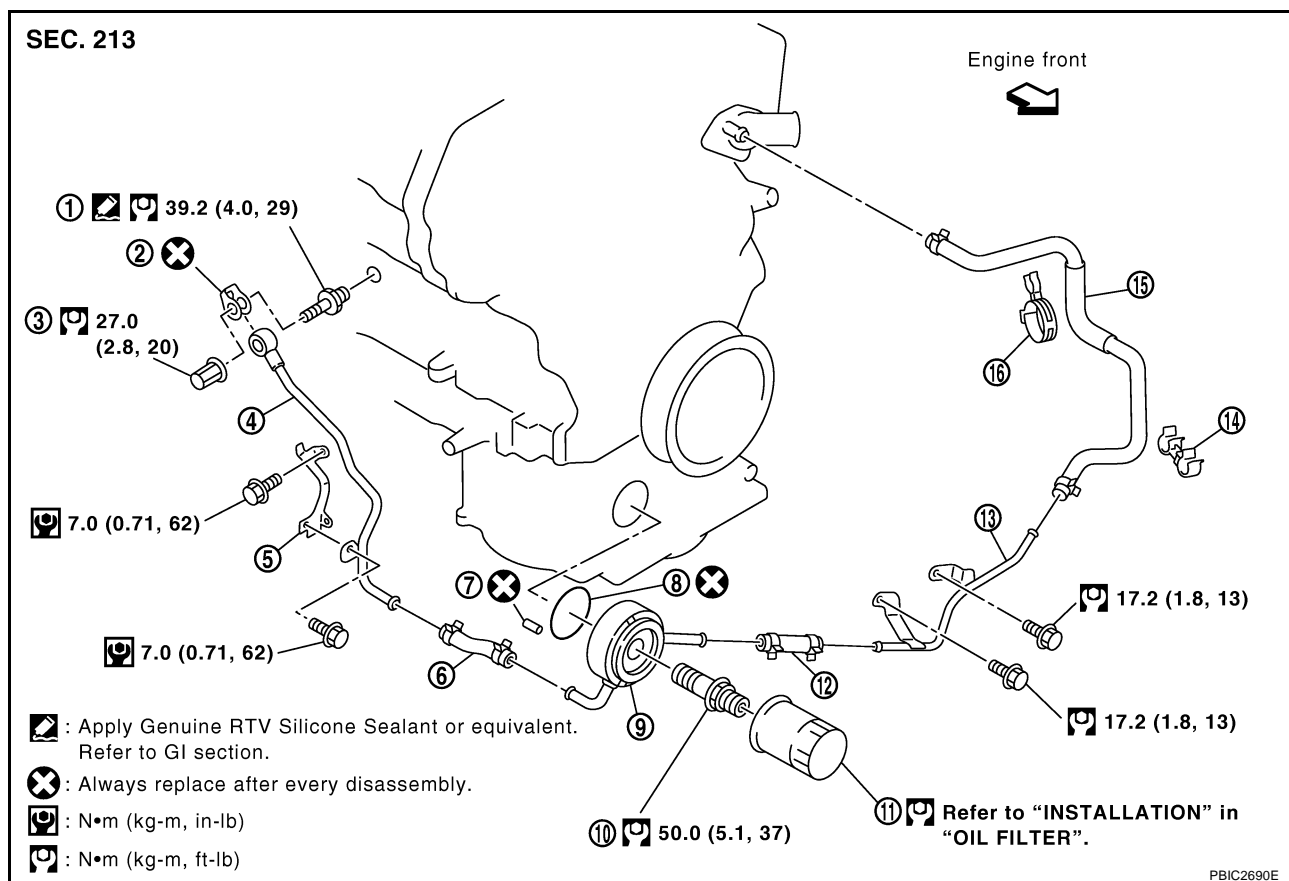

- |                    |                  |                     |
|--------------------|------------------|---------------------|
| 1. Connector bolt  | 2. Copper gasket | 3. Water drain plug |
| 4. Water pipe      | 5. Bracket       | 6. Water hose       |
| 7. Relief valve    | 8. O-ring        | 9. Oil cooler       |
| 10. Connector bolt | 11. Oil filter   | 12. Water hose      |
| 13. Water pipe     | 14. Clamp        | 15. Water hose      |
| 16. Clamp          |                  |                     |

#### **WARNING:**

**Be careful not to get burn yourself, as engine oil and engine coolant may be hot.**

#### **REMOVAL**

##### **NOTE:**

When remove oil cooler only, step 2 is unnecessary.

1. Remove splash guard (RH).
2. Drain engine coolant from radiator and cylinder block. Refer to [CO-9, "Changing Engine Coolant"](#) and [EM-113, "DISASSEMBLY"](#).

##### **NOTE:**

Perform this step when removing water pipes.

3. Remove oil filter. Refer to [LU-9, "OIL FILTER"](#).

##### **CAUTION:**

**Do not spill engine oil on drive belt.**

4. Disconnect water hoses from oil cooler.
  - When removing oil cooler only, pinching water hoses near oil cooler to prevent engine coolant from spilling out.
  - Remaining engine coolant in piping will come out. Use a tray to collect it.

# OIL COOLER

## CAUTION:

- Perform this step when the engine is cold.
- Do not spill engine coolant on drive belts.

5. Remove connector bolt, and remove oil cooler.

## CAUTION:

Do not spill engine oil to rubber parts such as drive belts and engine mounting insulator.

6. Remove water pipes, as necessary.

## INSPECTION AFTER REMOVAL

### Oil Cooler

Check oil cooler for cracks. Check oil cooler for clogging by blowing through engine coolant inlet. If necessary, replace oil cooler.

### Relief Valve

Inspect relief valve for movement, cracks and breaks by pushing the ball. If replacement is necessary, remove relief valve by prying it out with a suitable tool. Install a new relief valve in place by tapping it.

## INSTALLATION

Note the following, and install in the reverse order of removal.

- Make sure that no foreign objects are adhering to the installation surfaces of oil cooler and oil pan (upper).
- Align cutout on oil cooler with protrusion on oil pan (upper) side, and tighten connector bolt.

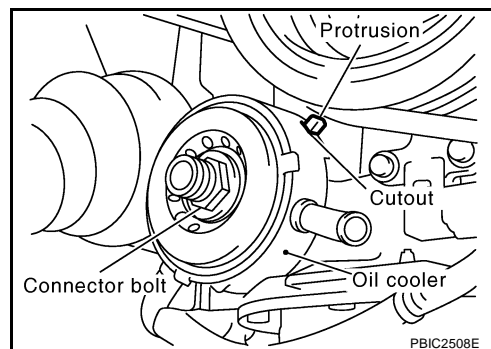

## INSPECTION AFTER INSTALLATION

1. Check the engine oil level and the engine coolant level and add engine oil and engine coolant. Refer to [LU-6, "ENGINE OIL"](#) and [CO-9, "ENGINE COOLANT"](#).
2. Start the engine, and check there is no leaks of engine oil or engine coolant.
3. Stop the engine and wait for 10 minutes.
4. Check the engine oil level and the engine coolant level again. Refer to [LU-6, "ENGINE OIL"](#) and [CO-9, "ENGINE COOLANT"](#).



# OIL PUMP

## INSPECTION AFTER DISASSEMBLY

### Oil Pump Clearance

- Measure the clearance with feeler gauge.
  - Clearance between oil pump outer rotor and oil pump body (position "1")  
**Standard : 0.114 - 0.260 mm (0.0045 - 0.0102 in)**
  - Tip clearance between oil pump inner rotor and oil pump outer rotor (position "2")  
**Standard : Below 0.180 mm (0.0071 in)**

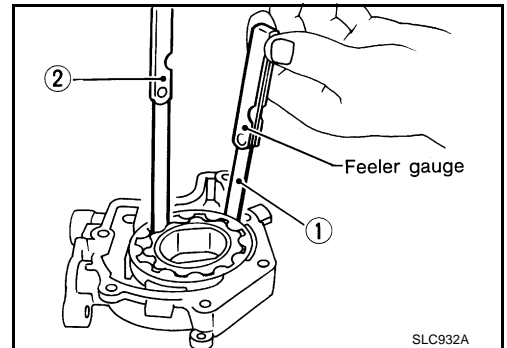

- Measure the clearance with feeler gauge and straightedge.
  - Side clearance between oil pump inner rotor and oil pump body (position "3")  
**Standard : 0.030 - 0.070 mm (0.0012 - 0.0028 in)**
  - Side clearance between oil pump outer rotor and oil pump body (position "4")  
**Standard : 0.050 - 0.110 mm (0.0020 - 0.0043 in)**

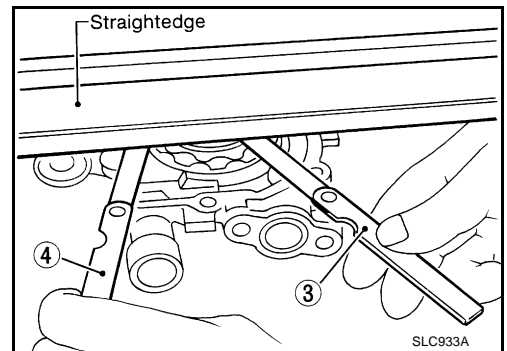

- Calculate the clearance between oil pump inner rotor and oil pump body as follows:

### OIL PUMP BODY INNER DIAMETER

- Measure the inner diameter of oil pump body with inside micrometer. (Position "5")

### OIL PUMP INNER ROTOR OUTER DIAMETER

- Measure the outer diameter of protruded portion of oil pump inner rotor with micrometer. (Position "6")

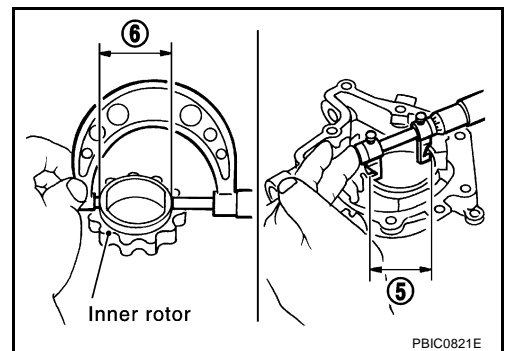

### OIL PUMP INNER ROTOR TO OIL PUMP BODY CLEARANCE

- (Clearance) = (Oil pump body inner diameter) – (Oil pump inner rotor outer diameter)  
**Standard : 0.045 - 0.091 mm (0.0018 - 0.0036 in)**

- If measured/calculated values are out of the standard, replace oil pump assembly.

A  
LU  
C  
D  
E  
F  
G  
H  
I  
J  
K  
L  
M

# OIL PUMP

## Regulator Valve Clearance

(Clearance) = (Valve hole diameter) – (Regulator valve outer diameter)

**Standard : 0.040 - 0.097 mm (0.0016 - 0.0038 in)**

- If the calculated value is out of the standard, replace oil pump assembly.

### CAUTION:

- Coat regulator valve with engine oil.
- Make sure that it falls smoothly into valve hole by its own weight.

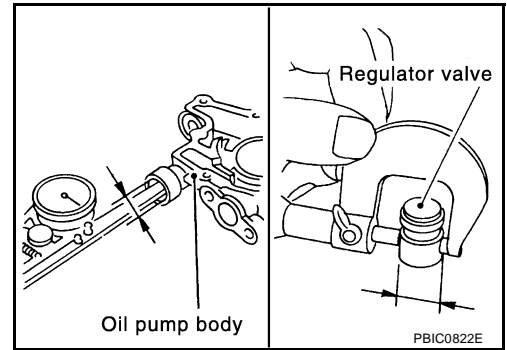

## ASSEMBLY

Note the following, and assemble in the reverse order of disassemble.

- Install oil pump inner rotor with the groove faced to oil pump cover side.

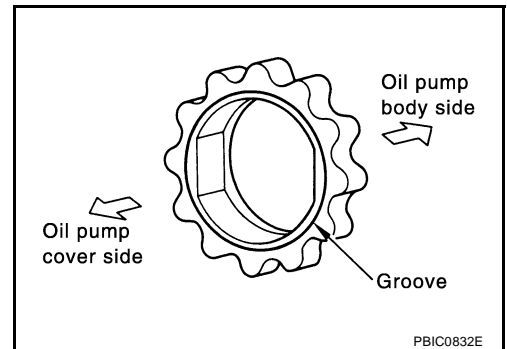

# SERVICE DATA AND SPECIFICATIONS (SDS)

## SERVICE DATA AND SPECIFICATIONS (SDS)

PFP:00030

### Standard and Limit OIL PRESSURE

ABS004RF

Engine speed (rpm)	Approximate discharge pressure* [kPa (kg/cm <sup>2</sup> , psi)]
Idle speed	More than 98 (1.0, 14)
2,000	More than 294 (3.0, 43)

\*: Engine oil temperature at 80°C (176°F)

### ENGINE OIL CAPACITY (APPROXIMATE)

Unit: ℓ (US qt, Imp qt)

Drain and refill	With oil filter change	4.0 (4-1/4, 3-1/2)
	Without oil filter change	3.7 (3-7/8, 3-1/4)
Dry engine (Overhaul)		5.0 (5-1/4, 4-3/8)

### OIL PUMP

Unit: mm (in)

Oil pump body to oil pump outer rotor radial clearance	0.114 - 0.260 (0.0045 - 0.0102)
Oil pump inner rotor to oil pump outer rotor tip clearance	Below 0.180 (0.0071)
Oil pump body to oil pump inner rotor side clearance	0.030 - 0.070 (0.0012 - 0.0028)
Oil pump body to oil pump outer rotor side clearance	0.050 - 0.110 (0.0020 - 0.0043)
Oil pump inner rotor to oil pump body clearance	0.045 - 0.091 (0.0018 - 0.0036)

### REGULATOR VALVE

Unit: mm (in)

Regulator valve to oil pump body clearance	0.040 - 0.097 (0.0016 - 0.0038)
--	---------------------------------

# SERVICE DATA AND SPECIFICATIONS (SDS)

---