

SECTION **EX** EXHAUST SYSTEM

CONTENTS

PREPARATION	2	Checking Exhaust System	3	F
Commercial Service Tools	2	Removal and Installation	3	
EXHAUST SYSTEM	3	REMOVAL	3	
		INSTALLATION	4	G
		INSPECTION AFTER INSTALLATION	4	

PREPARATION

PREPARATION

PFP:00002

Commercial Service Tools

ABS0033T

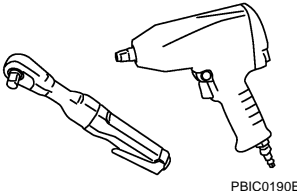
Tool name	Description
Power tool  PBIC0190E	Loosening nuts and bolts

EXHAUST SYSTEM

EXHAUST SYSTEM

PFP:20100

Checking Exhaust System

ABS0033U

Check exhaust pipes, muffler and mounting for improper attachment, leaks, cracks, damage or deterioration.

- If anything found, repair or replace damage parts.

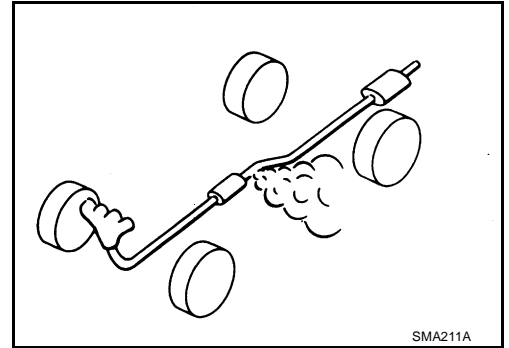

Removal and Installation

ABS0033V

WARNING:

Be careful not to cut your hand on heat insulator edge.

CAUTION:

- Be sure to use genuine exhaust system parts or equivalents which are specially designed for heat resistance, corrosion resistance, and shape.
- Perform the operation with the exhaust system fully cooled down because the system will be hot just after engine stops.

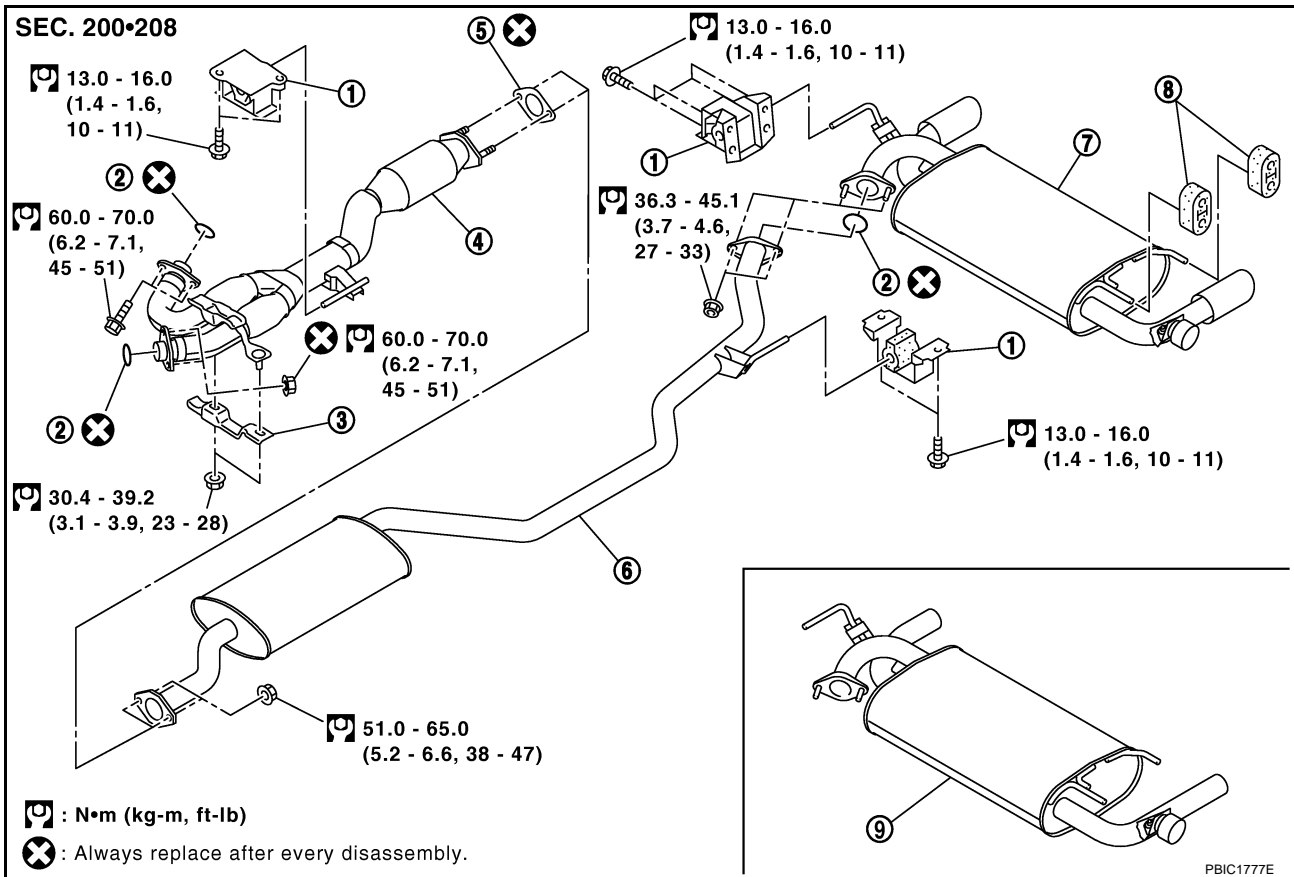

- | | | |
|-----------------------|--------------------|-------------------------------|
| 1. Mounting bracket | 2. Ring gasket | 3. Exhaust front tube bracket |
| 4. Exhaust front tube | 5. Gasket | 6. Center muffler |
| 7. Main muffler | 8. Mounting rubber | 9. Main muffler (GXE grade) |

REMOVAL

Disconnect each joint and mounting using power tool.

EXHAUST SYSTEM

INSTALLATION

Note the following, and install in the reverse order of removal.

- If exhaust front tube stud bolts were removed, and install them and tighten to the specified torque below.

 : 14.7 N·m (1.5 kg·m, 11 ft·lb)

CAUTION:

- Always replace exhaust tube gaskets with new ones when reassembling.
- If heat insulator is badly deformed, repair or replace it. If deposits such as mud pile up on the heat insulator, remove them.
- When installing heat insulator avoid large gaps or interference between heat insulator and each exhaust pipe.
- Remove deposits from the sealing surface of each connection. Connect them securely to avoid gases leakage.
- Temporarily tighten mounting nuts and bolts on the exhaust manifold side, and mounting bolts and nuts on the vehicle side. Check each part for unusual interference, and then tighten them to the specified torque.
- When installing each mounting rubber, avoid twisting or unusual extension in up/down and right/left directions.

INSPECTION AFTER INSTALLATION

- Make sure that clearance between tail tube and rear bumper is even.
- With engine running, check exhaust tube joints for gases leakage and unusual noises.
- Make sure that mounting brackets and mounting rubbers are installed properly and free from undue stress. Improper installation could result in excessive noise and vibration.