



Rear Main Oil Seal

REMOVAL & INSTALLATION

Z24i Engine

1. Remove the transmission assembly.
2. If equipped, remove the clutch assembly from the flywheel.
3. Remove the flywheel or flexplate.
4. Remove the rear main oil seal from around the crankshaft.

To install:

5. Apply lithium grease around the sealing lip of the oil seal, then install the seal around the crankshaft using a suitable tool.
6. Install the flywheel or flexplate. If equipped, install the clutch assembly.
7. Install the transmission assembly.
8. Check all fluid levels, start the engine and check for any leaks. Road test the vehicle for proper operation.

Fig. 1: Removing the rear main oil seal — Z24i engine

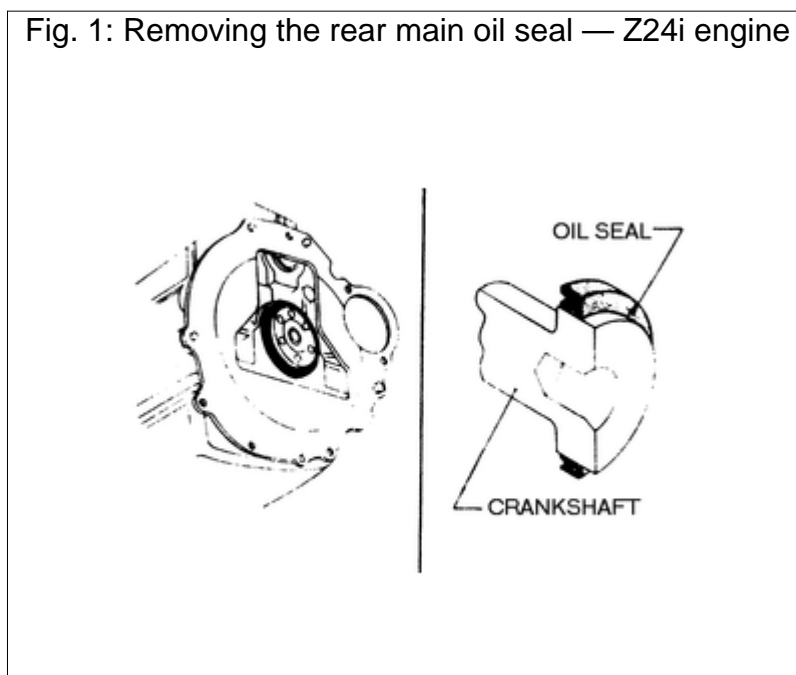

Fig. 2: Installing the rear main oil seal — Z24i engine



KA24E, VG30i and VG30E Engines

1. Remove the flywheel or flexplate.
2. Remove the rear oil seal retainer from the rear of the engine.
3. Pry the oil seal from the oil seal retainer, using a small prybar.

To install:

4. Clean the gasket mounting surfaces.
5. Apply oil to the sealing lip and the mounting surface of the new oil seal, then press the seal into the oil seal retainer. Install the oil seal retainer/seal.
6. Install the flywheel or flexplate.

Fig. 3: Remove all traces of sealant from the retainer before installation

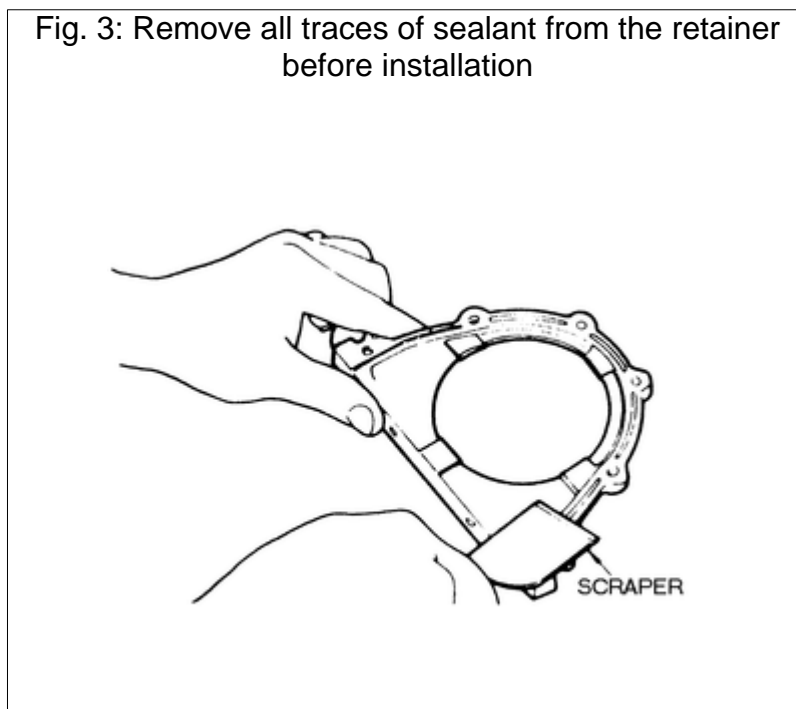

Fig. 4: Removing the oil seal from retainer

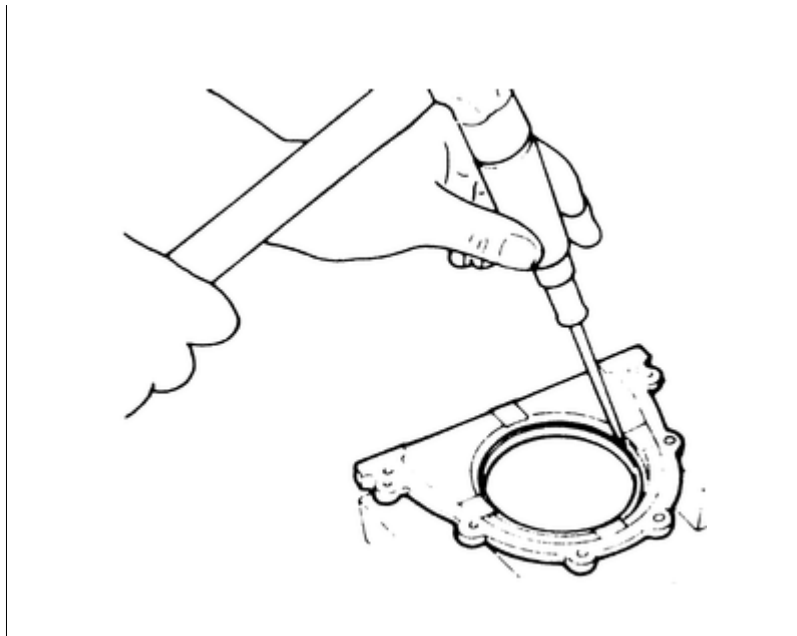

Fig. 5: Installing the rear oil seal in the retainer

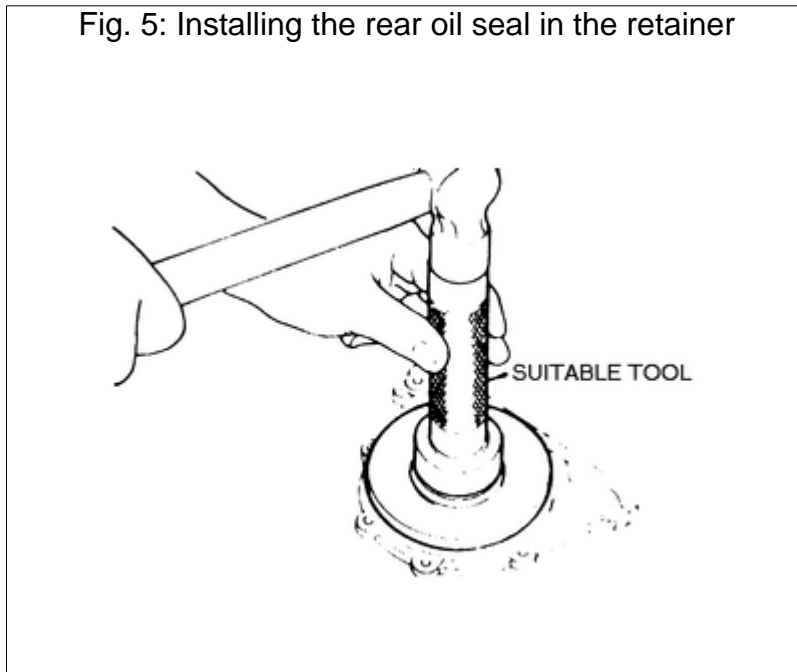

Fig. 6: Apply liquid sealant to the oil seal retainer

