



Differential Carrier

REMOVAL & INSTALLATION

1. Raise the front of the vehicle and support it with jackstands.
2. Remove the drain plug and drain the differential gear oil.

Fig. 1: Remove the front final drive unit with mounting member still attached

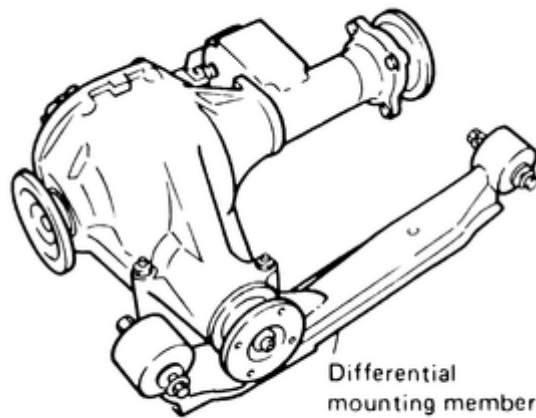

Fig. 2: Installing the front final drive unit

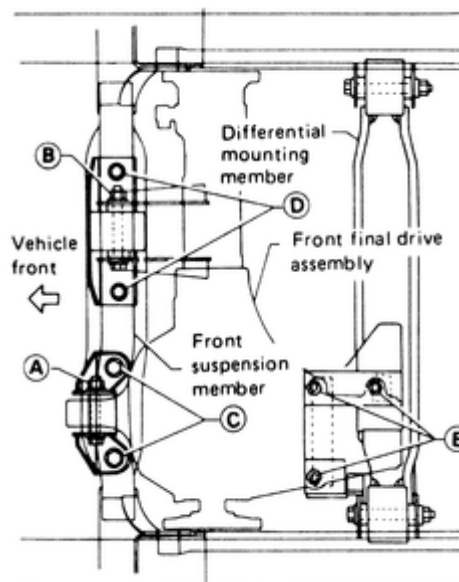

Fig. 3: Removing the front final drive unit using the correct equipment



3. Disconnect the axle shafts at the differential.
4. Remove the front driveshaft.
5. Position a floor jack under the differential and raise it just enough to support the carrier.
6. Loosen all the engine mount bolts, position another floor jack under the engine and raise it just enough to release the pressure on the mounts.
7. Remove all mounting bolts and lower the differential carrier down and away from the vehicle.

To install:

8. Install the carrier and temporarily tighten nuts **A** and **B**. Tighten bolts **C** and **D**, and nuts **A**, **B** and **E** in order, to 50–64 ft. lbs. (68–87 Nm).
9. Lower the engine and tighten the engine mount bolts.
10. Install the driveshaft and axle shafts.
11. Remove the jackstands, lower the vehicle and fill the differential with gear oil.

